

### **ServoDisk® Motors**

ver 1485.0

**Nominal Torque:** 14 ... 320 Ncm  
**Rated Voltage:** 17 ... 128 VDC  
**Nominal Output:** 43 ... 1000 W  
**Speed:** 0 ... 3000 ... 5000 min<sup>-1</sup>

- Unique ServoDisk armature for high performance
- Neodymium Magnet Technology
- Ultra-Thin compact size for easy design integration
- Fast acceleration for higher throughput
- Wide speed range for maximum flexibility
- Zero cogging for smooth operation
- Available with or without integrated tachometer

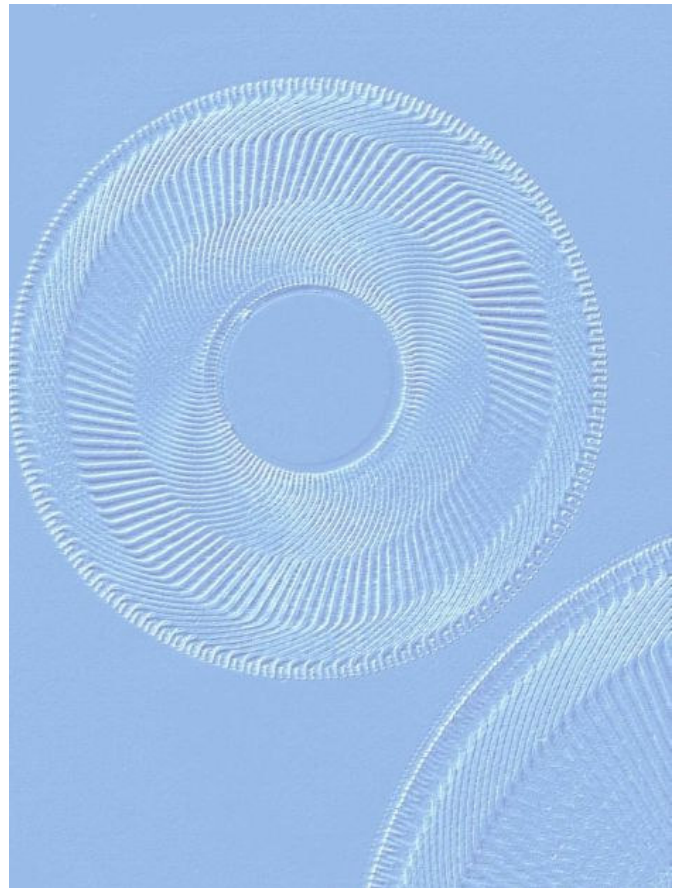

#### **Printed Motors GmbH**

Industriestraße 20

74909 Meckesheim

Tel. +49(0)6226/7870-0

Fax +49(0)6226/7870-29

Email [info@printedmotors.com](mailto:info@printedmotors.com)

Web [www.printedmotors.com](http://www.printedmotors.com)

## **Printed Motors**



## DC-Servomotor KN 06 M4 inch version

### Characteristics

#### Rated Values <sup>1</sup>

Nominal torque	$M_N$	13,7	Ncm
Nominal speed <sup>2</sup>	$n_N$	3000	min <sup>-1</sup>
Nominal output <sup>2</sup>	$P_N$	43	W
Terminal voltage	$U_N$	17,3	V
Nominal current	$I_N$	4,9	A

#### Motor Performance

Peak torque <sup>3</sup>	$M_{max}$	144	Ncm
Max. peak current	$I_{max}$	48	A
Acceleration at peak torque	$a_{max}$	240	10 <sup>3</sup> rad/s <sup>2</sup>
Stall torque	$M_0$	12,3	Ncm
Current at stall torque	$I_0$	4,4	A
Max. load speed	$n_{max}$	4500	min <sup>-1</sup>
Max. no load speed	$n_0$	5000	min <sup>-1</sup>

#### Intrinsic Motor Constants

Torque constant	$K_T$	3,0	Ncm/A
Back E.M.F constant	$K_E$	3,15	V/10 <sup>3</sup> min <sup>-1</sup>
Viscous damping constant	$K_D$	0,11	Ncm/10 <sup>3</sup> min <sup>-1</sup>
Speed reg. at const. Voltage	$k_n$	89	min <sup>-1</sup> /Ncm
Average friction torque	$M_F$	1	Ncm
Terminal resistance (25 °C)	$R_A$	1,2	Ω
Armature (Cu-)resistance (25 °C)	$R_{Cu}$	0,94	Ω
Armature inductance (10 <sup>3</sup> Hz)	$L_A$	<0,08	mH
Mechanical time constant	$T_m$	6,2	ms
Electrical time constant	$T_e$	0,11	ms
Rotor inertia	$J$	0,06	kg cm <sup>2</sup>

#### Thermal Characteristics

Time const. armature-housing	$T_{th1}$	0,44	min
Time const. housing-ambient <sup>5</sup>	$T_{th2}$	12,2	min
Resistance armature-housing	$R_{th1}$	2,1	K/W
Resistance housing-ambient <sup>5</sup>	$R_{th2}$	1,5	K/W
Temp.-coeff. of back EMF	$C_{th}$	-0,11	%/K
Max. cont. armature temp.	$t_h$	155	°C

#### Physical Data

Number of magnet poles	2p	6	pcs
Number of commutator bars	z	82	pcs
Admitted shaft load, radial	$F_R$	90	N
Admitted shaft load, axial	$F_A$	45	N
Weight without extensions	m	0,6	kg

- <sup>1</sup>) for DC current with formfactor 1,05, uncooled execution, protection IP 54, ambient temperature +40 °C.
- <sup>2</sup>) Continuous operation S1 (VDE 530), part 1,4. Motor can be run at all points of the torque speed curve S1, continuous speed beyond 4000 min<sup>-1</sup> is not recommended, please check the torque speed curve.
- <sup>3</sup>) Incremental motion cycle S3, VDE 530, part 1,4. Pulse duration 50 ms, 1% of duty cycle.
- <sup>4</sup>) Point of intersection torque speed curve S1 with torque coordinate at speed zero. Permitted at very low speed < 1min<sup>-1</sup>. Works the motor with blocked shaft longer than 20 s, the stall current must be reduced to appr. 70%.
- <sup>5</sup>) Based upon mounted motors, heat transfer from motor to equipment.

#### Outline dimensions motor:

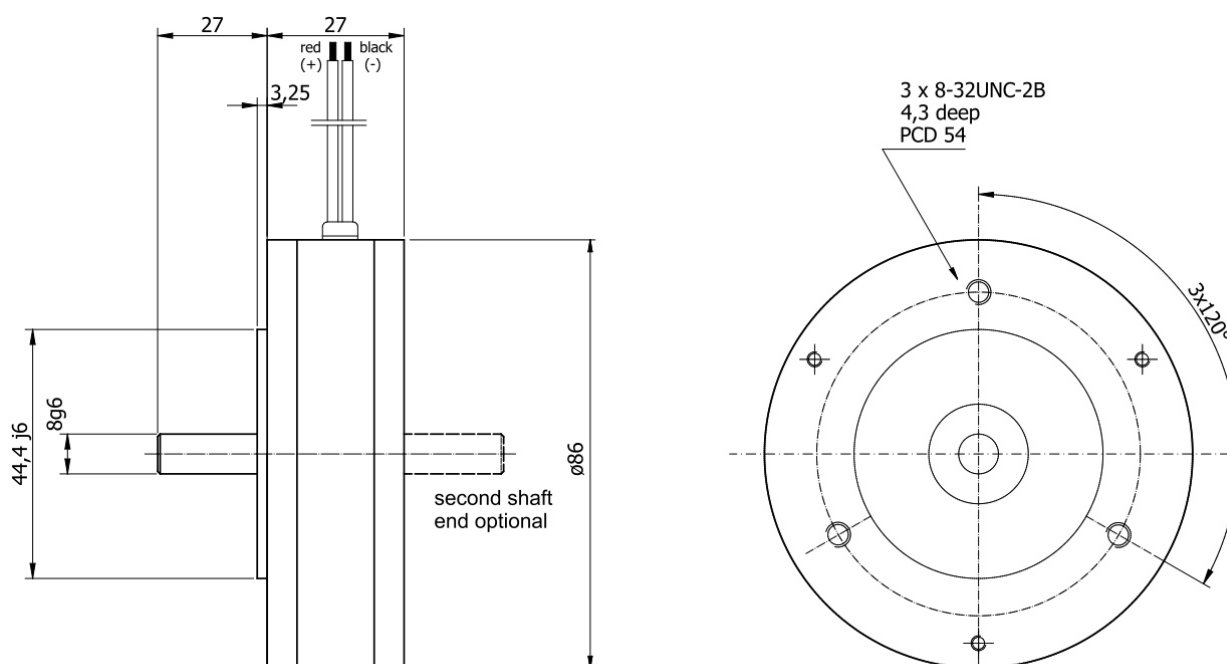

kn\_in\_en\_kn06m429

## DC-Servomotor KN 09 M4 inch version

### Characteristics

#### Rated Values <sup>1</sup>

Nominal torque	$M_N$	45	Ncm
Nominal speed <sup>2</sup>	$n_N$	3000	min <sup>-1</sup>
Nominal output <sup>2</sup>	$P_N$	141	W
Terminal voltage	$U_N$	30	V
Nominal current	$I_N$	7,8	A

#### Motor Performance

Peak torque <sup>3</sup>	$M_{max}$	489	Ncm
Max. peak current <sup>3</sup>	$I_{max}$	79	A
Acceleration at peak torque	$a_{max}$	123	10 <sup>3</sup> rad/s <sup>2</sup>
Stall torque <sup>4</sup>	$M_0$	43	Ncm
Current at stall torque <sup>4</sup>	$I_0$	7,5	A
Max. load speed	$n_{max}$	5000	min <sup>-1</sup>
Max. no load speed	$n_0$	6000	min <sup>-1</sup>

#### Intrinsic Motor Constants

Torque constant	$k_T$	7,3	Ncm/A
Back E.M.F constant	$k_E$	7,6	V/10 <sup>3</sup> min <sup>-1</sup>
Viscous damping constant	$k_D$	0,78	Ncm/10 <sup>3</sup> min <sup>-1</sup>
Speed regulation at const. Voltage	$k_n$	10	min <sup>-1</sup> /Ncm
Average friction torque	$M_F$	3	Ncm
Terminal resistance (+25 °C)	$R_A$	0,85	Ω
Armature (Cu) resistance (+25 °C)	$R_{Cu}$	0,66	Ω
Armature Inductance (10 <sup>3</sup> Hz)	$L_A$	<0,01	mH
Mechanical time constant	$T_m$	4,9	ms
Electrical time constant	$T_e$	0,15	ms
Rotor Inertia	$J$	0,396	kg cm <sup>2</sup>

#### Thermal Characteristics

Time const. armature-housing	$T_{th1}$	0,6	min
Time const. housing-ambient <sup>5</sup>	$T_{th2}$	19	min
Resistance armature-housing	$R_{th1}$	2	K/W
Resistance housing-ambient <sup>5</sup>	$R_{th2}$	1,5	K/W
Temp.- coeff. of back EMF	$C_{th}$	-0,11	%/K
Max. cont. armature temp.	$th$	155	°C

#### Physical Data

Number of magnet poles	2p	8	pcs
Number of commutator bars	z	117	pcs
Admitted shaft load, radial	$F_R$	180	N
Admitted shaft load, axial	$F_A$	150	N
Weight without extensions	m	1,4	kg

- <sup>1)</sup> for DC current with formfactor 1,05, uncooled execution, protection IP 54, ambient temperature +40 °C.
- <sup>2)</sup> Continuous operation S1 (VDE 530), part 1,4. Motor can be run at all points of the torque speed curve S1, continuous speed beyond 4000 min<sup>-1</sup> is not recommended, please check the torque speed curve.
- <sup>3)</sup> Incremental motion cycle S3, VDE 530, part 1,4. Pulse duration 50 ms, 1% of duty cycle.
- <sup>4)</sup> Point of intersection torque speed curve S1 with torque co-ordinate at speed zero. Permitted at very low speed < 1min<sup>-1</sup>. Works the motor with blocked shaft longer than 20 s, the stall current must be reduced to appr. 70%.
- <sup>5)</sup> Based upon mounted motors, heat transfer from motor to equipment.

Outline dimensions motor (in mm):

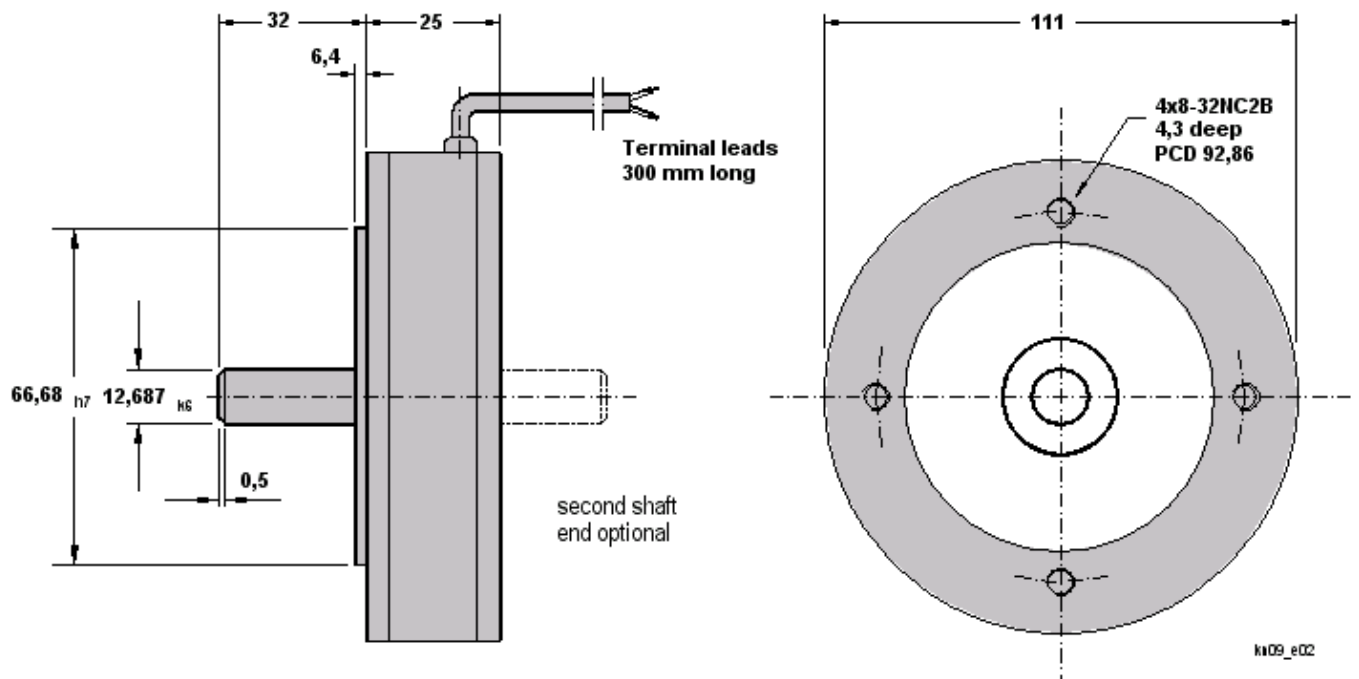

## DC-Servomotor KN 09 M4 T inch version

### Characteristics

#### Rated Values <sup>1</sup>

Nominal torque	$M_N$	42	Ncm
Nominal speed <sup>2</sup>	$n_N$	3000	min <sup>-1</sup>
Nominal output <sup>2</sup>	$P_N$	132	W
Terminal voltage	$U_N$	28	V
Nominal current	$I_N$	7,8	A

#### Motor Performance

Peak torque <sup>3</sup>	$M_{max}$	458	Ncm
Max. peak current <sup>3</sup>	$I_{max}$	79	A
Acceleration at peak torque	$a_{max}$	78	10 <sup>3</sup> rad/s <sup>2</sup>
Stall torque <sup>4</sup>	$M_0$	40	Ncm
Current at stall torque <sup>4</sup>	$I_0$	7,5	A
Max. load speed	$n_{max}$	5000	min <sup>-1</sup>
Max. no load speed	$n_0$	6000	min <sup>-1</sup>

#### Intrinsic Motor Constants

Torque constant	$k_T$	6,8	Ncm/A
Back E.M.F constant	$k_E$	7,1	V/10 <sup>3</sup> min <sup>-1</sup>
Viscous damping constant	$k_D$	0,73	Ncm/10 <sup>3</sup> min <sup>-1</sup>
Viscous damping constant	$k_n$	10	min <sup>-1</sup> /Ncm
Speed regulation at const. Voltage	$M_F$	3,2	Ncm
Terminal resistance (+25 °C)	$R_A$	0,85	$\Omega$
Armature (Cu) resistance (+25 °C)	$R_{Cu}$	0,66	$\Omega$
Armature Inductance (10 <sup>3</sup> Hz)	$L_A$	<0,01	mH
Mechanical time constant	$T_m$	8,4	ms
Electrical time constant	$T_e$	<0,05	ms
Rotor inertia	$J$	0,568	kg cm <sup>2</sup>

#### Thermal Characteristics

Time const. armature-housing	$T_{th1}$	0,6	min
Time const. housing-ambient <sup>5</sup>	$T_{th2}$	19	min
Resistance armature-housing	$R_{th1}$	2	K/W
Resistance housing-ambient <sup>5</sup>	$R_{th2}$	1,5	K/W
Temp.- coeff. of back EMF	$c_{th}$	-0,11	%/K
Max. cont. armature temp.	$th$	155	°C

#### Physical Data

Number of magnet poles	2p	8	pcs
Number of commutator bars	z	117	pcs
Admitted shaft load, radial	$F_R$	180	N
Admitted shaft load, axial	$F_A$	150	N
Weight without extensions	m	1,4	kg

#### Tachometer characteristics <sup>6</sup>

Output voltage (±5%)	U	3,5	V/10 <sup>3</sup> min <sup>-1</sup>
Max. ripple peak to peak	$U_{RH}$	3,0	%
Temperature coefficient of $K_E$	$c_T$	-0,1	%/K
Max. rated current	$I_L$	370	mA

- <sup>1</sup> for DC current with formfactor 1,05, uncooled execution, protection IP 54, ambient temperature +40 °C.
- <sup>2</sup> Continuous operation S1 (VDE 530), part 1,4. Motor can be run at all points of the torque speed curve S1, continuous speed beyond 4000 min<sup>-1</sup> is not recommended, please check the torque speed curve.
- <sup>3</sup> Incremental motion cycle S3, VDE 530, part 1,4. Pulse duration 50 ms, 1% of duty cycle.
- <sup>4</sup> Point of intersection torque speed curve S1 with torque co-ordinate at speed zero. Permitted at very low speed < 1min<sup>-1</sup>. Works the motor with blocked shaft longer than 20 s, the stall current must be reduced to appr. 70%.
- <sup>5</sup> Based upon mounted motors, heat transfer from motor to equipment.
- <sup>6</sup> Tacho must not operate without load,  $R_L, min = 10k\Omega$

#### Outline dimensions motor (in mm):

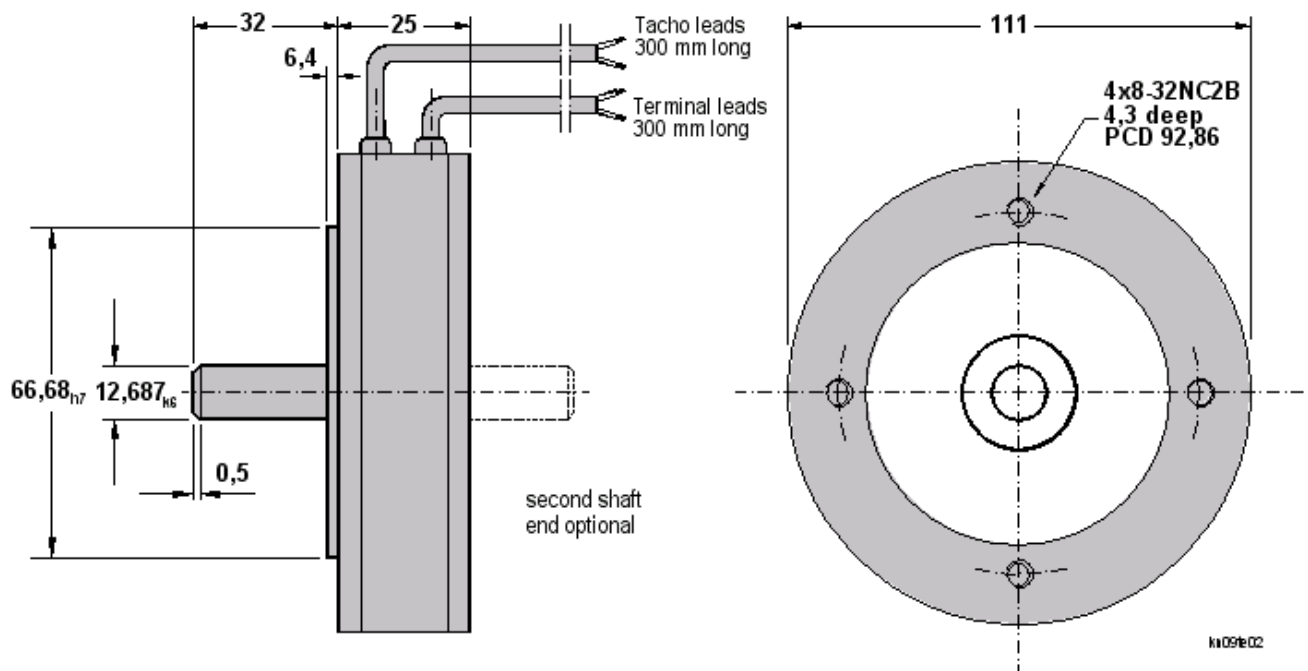

## DC-Servomotor KN 12 M4 inch version

### Characteristics

#### Rated Values <sup>1</sup>

Nominal torque	$M_N$	136	Ncm
Nominal speed <sup>2</sup>	$n_N$	3000	min <sup>-1</sup>
Nominal output <sup>2</sup>	$P_N$	426	W
Terminal voltage	$U_N$	46	V
Nominal current	$I_N$	9,2	A

#### Motor Performance

Peak torque <sup>3</sup>	$M_{max}$	1438	Ncm
Max. peak current <sup>3</sup>	$I_{max}$	92	A
Acceleration at peak torque	$a_{max}$	107	10 <sup>3</sup> rad/s <sup>2</sup>
Stall torque <sup>4</sup>	$M_0$	124	Ncm
Current at stall torque <sup>4</sup>	$I_0$	8,8	A
Max. load speed	$n_{max}$	5000	min <sup>-1</sup>
Max. no load speed	$n_0$	6000	min <sup>-1</sup>

#### Intrinsic Motor Constants

Torque constant	$k_T$	14,0	Ncm/A
Back E.M.F constant	$k_E$	14,7	V/10 <sup>3</sup> min <sup>-1</sup>
Viscous damping constant	$k_D$	1,9	Ncm/10 <sup>3</sup> min <sup>-1</sup>
Speed regulation at const. Voltage	$k_n$	4,44	min <sup>-1</sup> /Ncm
Average friction torque	$M_F$	3,7	Ncm
Terminal resistance (+25 °C)	$R_A$	0,75	Ω
Armature (Cu) resistance (+25 °C)	$R_{Cu}$	0,61	Ω
Armature Inductance (10 <sup>3</sup> Hz)	$L_A$	<0,05	mH
Mechanical time constant	$T_m$	4,5	ms
Electrical time constant	$T_e$	<0,07	ms
Rotor inertia	$J$	1,343	kg cm <sup>2</sup>

#### Thermal Characteristics

Time const. armature-housing	$T_{th1}$	1	min
Time const. housing-ambient <sup>5</sup>	$T_{th2}$	32	min
Resistance armature-housing	$R_{th1}$	1,6	K/W
Resistance housing-ambient <sup>5</sup>	$R_{th2}$	1,2	K/W
Temp.- coeff. of back EMF	$c_{th}$	-0,11	%/K
Max. cont. armature temp.	$th$	155	°C

#### Physical Data

Number of magnet poles	2p	8	pcs
Number of commutator bars	z	141	pcs
Admitted shaft load, radial	$F_R$	220	N
Admitted shaft load, axial	$F_A$	180	N
Weight without extensions	m	2,8	kg

- <sup>1</sup>) for DC current with formfactor 1,05, uncooled execution, protection IP 54, ambient temperature +40 °C.
- <sup>2</sup>) Continuous operation S1 (VDE 530), part 1,4. Motor can be run at all points of the torque speed curve S1, continuous speed beyond 4000 min<sup>-1</sup> is not recommended, please check the torque speed curve.
- <sup>3</sup>) Incremental motion cycle S3, VDE 530, part 1,4. Pulse duration 50 ms, 1% of duty cycle.
- <sup>4</sup>) Point of intersection torque speed curve S1 with torque coordinate at speed zero. Permitted at very low speed < 1min<sup>-1</sup>. Works the motor with blocked shaft longer than 20 s, the stall current must be reduced to appr. 70%.
- <sup>5</sup>) Based upon mounted motors, heat transfer from motor to equipment.

Outline dimensions motor (in mm):

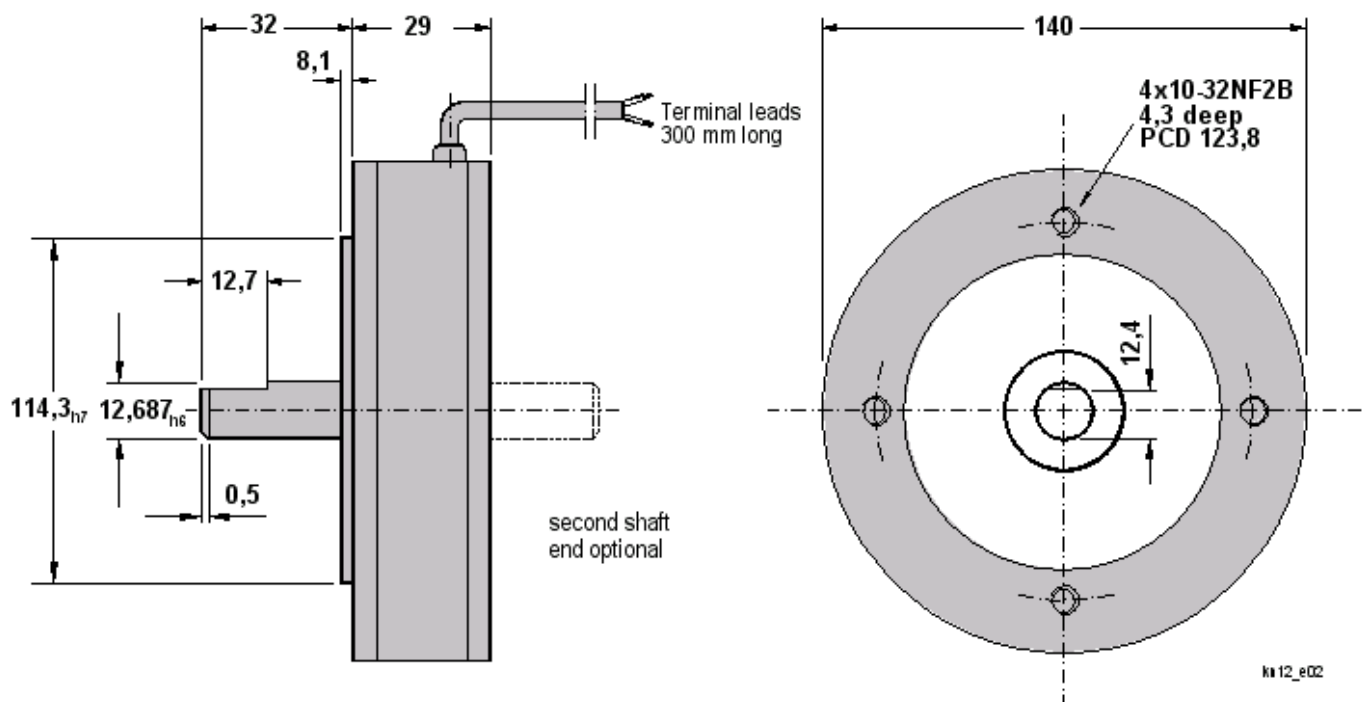



## DC-Servomotor KN 12 M4 T inch version

### Characteristics

#### Rated Values <sup>1</sup>

Nominal torque	$M_N$	128	Ncm
Nominal speed <sup>2</sup>	$n_N$	3000	min <sup>-1</sup>
Nominal output <sup>2</sup>	$P_N$	401	W
Terminal voltage	$U_N$	46	V
Nominal current	$I_N$	9,3	A

#### Motor Performance

Peak torque <sup>3</sup>	$M_{max}$	1352	Ncm
Max. peak current <sup>3</sup>	$I_{max}$	92	A
Acceleration at peak torque	$a_{max}$	123	10 <sup>3</sup> rad/s <sup>2</sup>
Stall torque <sup>4</sup>	$M_0$	123	Ncm
Current at stall torque <sup>4</sup>	$I_0$	8,9	A
Max. load speed	$n_{max}$	5000	min <sup>-1</sup>
Max. no load speed	$n_0$	6000	min <sup>-1</sup>

#### Intrinsic Motor Constants

Torque constant	$k_T$	13,8	Ncm/A
Back E.M.F constant	$k_E$	14,4	V/10 <sup>3</sup> min <sup>-1</sup>
Viscous damping constant	$k_D$	1,7	Ncm/10 <sup>3</sup> min <sup>-1</sup>
Speed regulation at const. Voltage	$k_n$	4,44	min <sup>-1</sup> /Ncm
Average friction torque	$M_F$	3,7	Ncm
Terminal resistance (+25 °C)	$R_A$	0,75	Ω
Armature (Cu) resistance (+25 °C)	$R_{Cu}$	0,61	Ω
Armature Inductance (10 <sup>3</sup> Hz)	$L_A$	<0,05	mH
Mechanical time constant	$T_m$	7,1	ms
Electrical time constant	$T_e$	<0,07	ms
Rotor Inertia	$J$	1,838	kg cm <sup>2</sup>

#### Thermal Characteristics

Time const. armature-housing	$T_{th1}$	1	min
Time const. housing-ambient <sup>5</sup>	$T_{th2}$	32	min
Resistance armature-housing	$R_{th1}$	1,6	K/W
Resistance housing-ambient <sup>5</sup>	$R_{th2}$	1,2	K/W
Temp.-coeff. of back EMF	$C_{th}$	-0,11	%/K
Max. cont. armature temp.	$t_h$	155	°C

#### Physical Data

Number of magnet poles	2p	8	pcs
Number of commutator bars	z	141	pcs
Admitted shaft load, radial	$F_R$	220	N
Admitted shaft load, axial	$F_A$	180	N
Weight without extensions	m	2,8	kg

#### Tachometer characteristics <sup>6</sup>

Output voltage (±5%)	U	6,6	V/10 <sup>3</sup> min <sup>-1</sup>
Max. ripple peak to peak	$U_{RH}$	3,0	%
Temperature coefficient of $K_E$	$C_T$	-0,1	%/K
Max. rated current	$I_L$	100	mA

- <sup>1</sup>) for DC current with formfactor 1,05, uncooled execution, protection IP 54, ambient temperature +40 °C.
- <sup>2</sup>) Continuous operation S1 (VDE 530), part 1,4. Motor can be run at all points of the torque speed curve S1, continuous speed beyond 4000 min<sup>-1</sup> is not recommended, please check the torque speed curve.
- <sup>3</sup>) Incremental motion cycle S3, VDE 530, part 1,4. Pulse duration 50 ms, 1% of duty cycle.
- <sup>4</sup>) Point of intersection torque speed curve S1 with torque co-ordinate at speed zero. Permitted at very low speed < 1min<sup>-1</sup>. Works the motor with blocked shaft longer than 20 s, the stall current must be reduced to appr. 70%.
- <sup>5</sup>) Based upon mounted motors, heat transfer from motor to equipment.
- <sup>6</sup>) Tacho must not operate without load,  $R_L, min = 10kΩ$

Outline dimensions motor (in mm):

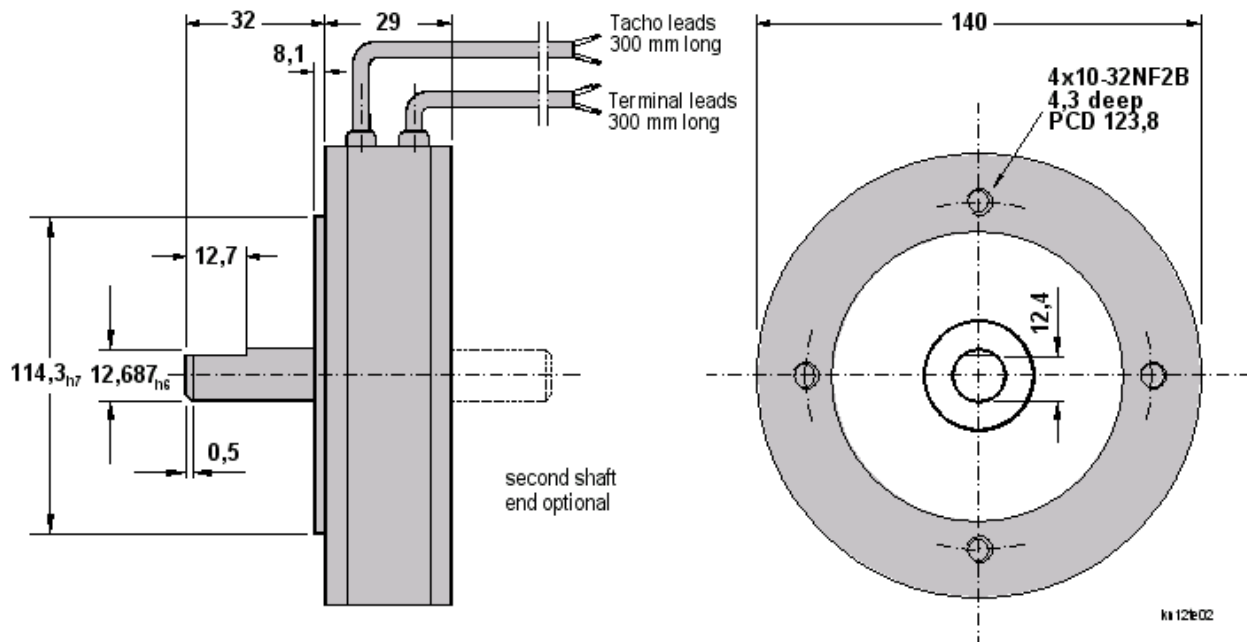

## DC-Servomotor KN 16 M4 inch version

### Characteristics

#### Rated Values <sup>1</sup>

Nominal torque	$M_N$	320	Ncm
Nominal speed <sup>2</sup>	$n_N$	3000	min <sup>-1</sup>
Nominal output <sup>2</sup>	$P_N$	1000	W
Terminal voltage	$U_N$	128	V
Nominal current	$I_N$	9,3	A

#### Motor Performance

Peak torque <sup>3</sup>	$M_{max}$	3500	Ncm
Max. peak current <sup>3</sup>	$I_{max}$	100	A
Acceleration at peak torque	$a_{max}$	63	10 <sup>3</sup> rad/s <sup>2</sup>
Stall torque <sup>4</sup>	$M_0$	325	Ncm
Current at stall torque <sup>4</sup>	$I_0$	8,8	A
Max. load speed	$n_{max}$	4000	min <sup>-1</sup>
Max. no load speed	$n_0$	6000	min <sup>-1</sup>

#### Intrinsic Motor Constants

Torque constant	$k_T$	38,4	Ncm/A
Back E.M.F constant	$k_E$	40,2	V/10 <sup>3</sup> min <sup>-1</sup>
Viscous damping constant	$k_D$	6,5	Ncm/10 <sup>3</sup> min <sup>-1</sup>
Speed regulation at const. Voltage	$k_n$	0,65	min <sup>-1</sup> /Ncm
Average Friction Torque	$M_F$	6,9	Ncm
Terminal resistance (+25 °C)	$R_A$	0,94	Ω
Armature (Cu) resistance (+25 °C)	$R_{Cu}$	0,74	Ω
Armature Inductance (10 <sup>3</sup> Hz)	$L_A$	<0,06	mH
Mechanical time constant	$T_m$	3,9	ms
Electrical time constant	$T_e$	<0,08	ms
Rotor inertia	$J$	5,95	kg cm <sup>2</sup>

#### Thermal Characteristics

Time const. armature-housing	$T_{th1}$	1,82	min
Time const. housing-ambient <sup>5</sup>	$T_{th2}$	32,8	min
Resistance armature-housing	$R_{th1}$	0,83	K/W
Resistance housing-ambient <sup>5</sup>	$R_{th2}$	0,59	K/W
Temp.- coeff. of back EMF	$c_{th}$	-0,08	%/K
Max. cont. armature temp.	$th$	155	°C

#### Physical Data

Number of magnet poles	2p	8	pcs
Number of commutator bars	z	162	pcs
Admitted shaft load, radial	$F_R$	440	N
Admitted shaft load, axial	$F_A$	420	N
Weight without extensions	m	7,9	kg

- <sup>1)</sup> for DC current with formfactor 1,05, uncooled execution, protection IP 54, ambient temperature +40 °C.  
<sup>2)</sup> Continuous operation S1 (VDE 530), part 1,4. Motor can be run at all points of the torque speed curve S1, continuous speed beyond 4000 min<sup>-1</sup> is not recommended, please check the torque speed curve.  
<sup>3)</sup> Incremental motion cycle S3, VDE 530, part 1,4. Pulse duration 50 ms, 1% of duty cycle.  
<sup>4)</sup> Point of intersection torque speed curve S1 with torque coordinate at speed zero. Permitted at very low speed < 1min<sup>-1</sup>. Works the motor with blocked shaft longer than 20 s, the stall current must be reduced to appr. 70%.  
<sup>5)</sup> Based upon mounted motors, heat transfer from motor to equipment.

Outline dimensions motor (in mm):

grey diagrammed hood optional

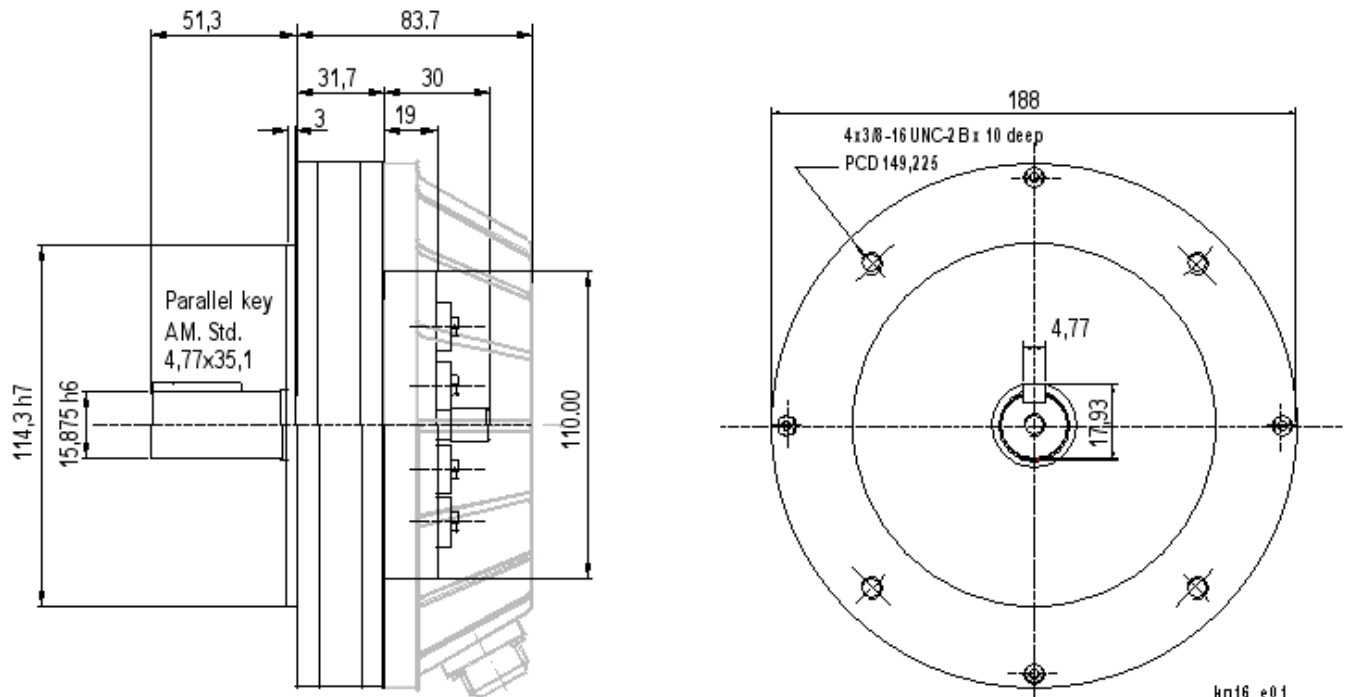

## DC-Servomotor KN 16 M4 T inch version

### Characteristics

#### Rated Values <sup>1</sup>

Nominal torque	$M_N$	290	Ncm
Nominal speed <sup>2</sup>	$n_N$	3000	min <sup>-1</sup>
Nominal output <sup>2</sup>	$P_N$	910	W
Terminal voltage	$U_N$	115	V
Nominal current	$I_N$	9,3	A

#### Motor Performance

Peak torque <sup>3</sup>	$M_{max}$	3280	Ncm
Max. peak current	$I_{max}$	100	A
Acceleration at peak torque	$a_{max}$	42	10 <sup>3</sup> rad/s <sup>2</sup>
Stall torque	$M_0$	305	Ncm
Current at stall torque	$I_0$	8,8	A
Max. load speed	$n_{max}$	4000	min <sup>-1</sup>
Max. no load speed	$n_0$	6000	min <sup>-1</sup>

#### Intrinsic Motor Constants

Torque constant	$k_T$	31,0	Ncm/A
Back E.M.F constant	$k_E$	32,5	V/10 <sup>3</sup> min <sup>-1</sup>
Viscous damping constant	$k_D$	9,8	Ncm/10 <sup>3</sup> min <sup>-1</sup>
Speed reg. at const. Voltage	$k_n$	1,59	min <sup>-1</sup> /Ncm
Average friction torque	$M_F$	11,2	Ncm
Terminal resistance (25 °C)	$R_A$	0,94	$\Omega$
Armature (Cu-)resistance (25 °C)	$R_{Cu}$	0,74	$\Omega$
Armature inductance (10 <sup>3</sup> Hz)	$L_A$	<0,01	mH
Mechanical time constant	$T_m$	5,9	ms
Electrical time constant	$T_e$	<0,08	ms
Rotor inertia	$J$	8,93	kg cm <sup>2</sup>

#### Thermal Characteristics

Time const. armature-housing	$T_{th1}$	1,82	min
Time const. housing-ambient <sup>5</sup>	$T_{th2}$	32,8	min
Resistance armature-housing	$R_{th1}$	0,83	K/W
Resistance housing-ambient <sup>5</sup>	$R_{th2}$	0,59	K/W
Temp.-coeff. of back EMF	$c_{th}$	-0,11	%/K
Max. cont. armature temp.	$th$	155	°C

#### Physical Data

Number of magnet poles	2p	8	pcs
Number of commutator bars	z	162	pcs
Admitted shaft load, radial	$F_R$	390	N
Admitted shaft load, axial	$F_A$	375	N
Weight without extensions	m	6,0	kg

#### Tachometer characteristics <sup>6</sup>

Output voltage ( $\pm 5\%$ )	$U$	16,5	V/10 <sup>3</sup> min <sup>-1</sup>
Max. ripple peak to peak	$U_{RH}$	3,0	%
Temperature coefficient of $K_E$	$c_T$	-0,1	%/K
Max. rated current	$I_L$	100	mA

- <sup>1)</sup> for DC current with formfactor 1,05, uncooled execution, protection IP 54, ambient temperature +40 °C.
- <sup>2)</sup> Continuous operation S1 (VDE 530), part 1,4. Motor can be run at all points of the torque speed curve S1, continuous speed beyond 4000 min<sup>-1</sup> is not recommended, please check the torque speed curve.
- <sup>3)</sup> Incremental motion cycle S3, VDE 530, part 1,4. Pulse duration 50 ms, 1% of duty cycle.
- <sup>4)</sup> Point of intersection torque speed curve S1 with torque co-ordinate at speed zero. Permitted at very low speed < 1min<sup>-1</sup>. Works the motor with blocked shaft longer than 20 s, the stall current must be reduced to appr. 70%.
- <sup>5)</sup> Based upon mounted motors, heat transfer from motor to equipment.
- <sup>6)</sup> Tacho must not operate without load,  $R_{L,min} = 10k\Omega$

#### Outline dimensions motor (in mm):

grey diagrammed hood optional

